



Split Rear

Leach™ Engineered Dual-Stream Collection

- 32 yd³ body size available
- Up to 1000 lbs/yd³ compaction
- 50/50, 40/60 or 60/40 split body configurations
- Flat floor design
- Single piece body walls for increased strength and seamless appearance
- Fully independent tailgates and ejector panels
- Hopper shape minimizes pre-compaction, reducing wear and maximizing payload
- Packer and Carrier Slide Shoes with Chromium overlay extend service life and reduce maintenance points
- Low load sill height of 6" below frame
- Fully integrated Labrie CNG system – roof, frame and back of cab mount – 50 to 100 DGE available



Body Specifications

Body Floor	1/4" 50W 50,000psi
Body Sides	10ga A1011 80,000psi
Body Roof	10ga A1011 80,000psi

Hopper Specifications

Hopper Size 60% side (yd ³)	1.4
Hopper Size 40% side (yd ³)	1
Hopper Opening Width 60% Side	45-7/8"
Hopper Opening Width 40% Side	32-3/8"
Hopper Opening Height	63"
Hopper Depth	15"
Loading Sill Below Chassis Frame	6"
Hopper Floor	3/16" 100QT 100,000psi (AR450, 175,000 psi optional)
Hopper Sides (upper)	3/16" 50W 50,000psi (AR450, 175,000 psi optional)
Hopper Sides (lower)	1/4" 50W 50,000psi (AR450, 175,000 psi optional)

Packer-Carrier Specifications

Compaction ratio (lbs/yd ³)	1000
Packer Panel Face Plate	1/4" 50W 50,000psi
Carrier Panel Face Plate	3/16" 50W 50,000psi

Hydraulic Specifications

Pump	Remote dual valve pump
Pump Capacity	56 gpm @ 1200 rpm
Max. Operating Pressure	3,000 psi
Oil Reservoir	94 gal

Cylinder Specifications

Ejector Cylinder (25yd ³)	3 stages 5-1/2" bore x 124-1/2" stroke
Ejector Cylinder (32yd ³)	5 stages 7-1/2" bore x 176-1/2" stroke
Packer Cylinders	3-1/4" bore x 2" rod x 32" stroke
Carrier Cylinders	3-3/4" bore x 1-3/4" rod x 35" stroke
Tailgate Cylinders	3" bore x 2" rod x 35-1/2" stroke

Note: Specifications subject to change without notice



Split Rear

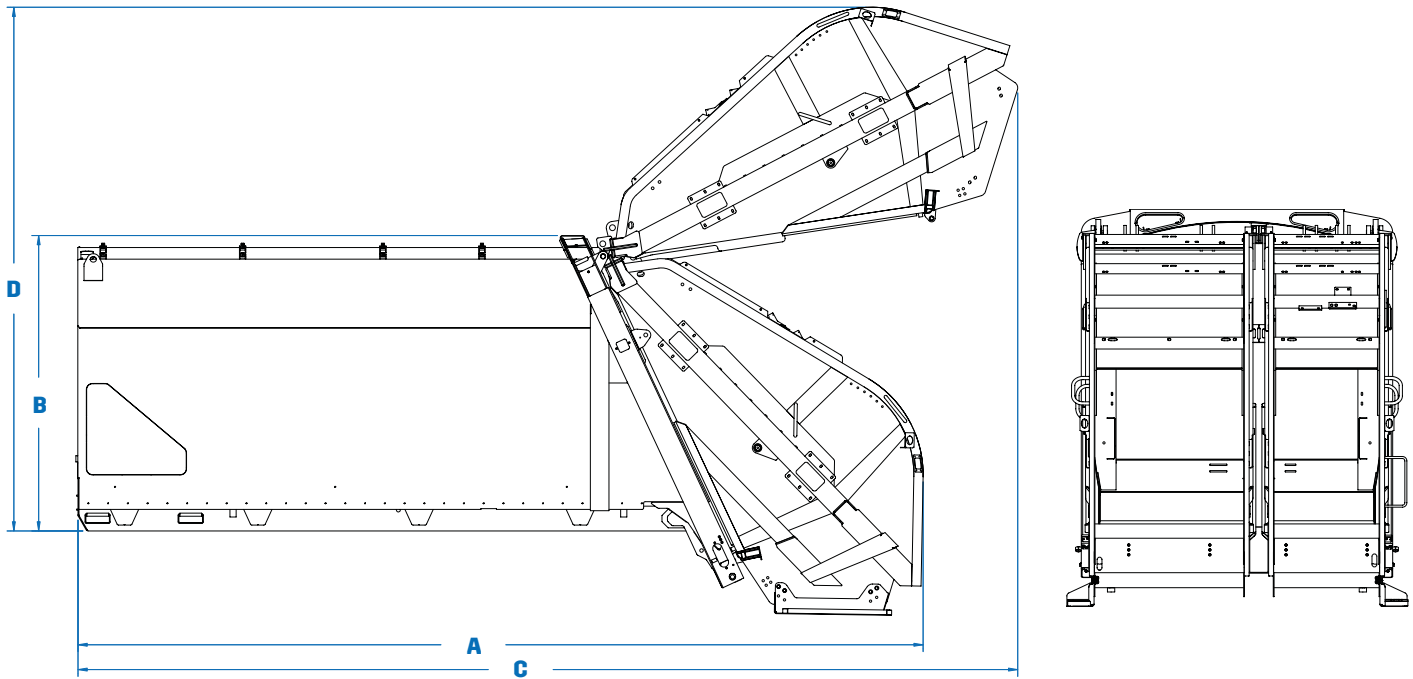

Body Dimensions	25yd ³	32yd ³
A. Overall Length, Tailgate Closed (in.)	273	326
Overall Width (in.)	102	102
B. Overall Height Above Frame, Tailgate Closed (in.)	95	95
C. Overall Length, Tailgate Open (in.)	303	356
D. Overall Height Above Frame, Tailgate Open (in.)	169	169

Performance Specifications	
Packer/Carrier Cycle Time	20-22 sec
Tailgate Open	10 sec @ 700 rpm
Tailgate Close	14 sec @ 700 rpm



DRIVE EXCELLENCE™

