



# Top Select™





# Top Select Series

VERSATILE CURBSIDE RECYCLING PIONEERED BY LABRIE

The Top Select, pioneered by Labrie™, is a recycling body designed for manual and semi-automated collection of residential recyclable material.

It stands as the first-ever recycling unit built and remains the best-selling unit in its class in North America, solidifying its status as a Labrie™ innovation and an industry staple.

## Laying the foundations for a truly exceptional product.

### LABRIE™ INNOVATIONS

With a strong emphasis on innovation, Labrie's engineering team has crafted a comprehensive range of customizable options to cater to even the most stringent customer requirements. We are poised and eager to embrace emerging industry trends and fulfill evolving customer demands. This perpetual cycle of innovation positions Labrie™ as the forefront leader in side loader solutions across North America.

### WEIGHT DISTRIBUTION

Over years of innovation, Labrie™ trucks prioritize ideal weight distribution in all models. Our ongoing objective is to achieve the perfect material balance, ensuring models collect more waste while maintaining the highest legal payload.



**ENVIROLINK™ HAS LAID THE FOUNDATIONS FOR A BRAND-NEW ERA IN TRUCK INTELLIGENCE.**

An improved multiplex network and analog system, cameras and monitors, scales, diagnostic tools, safety interlocks, alerts, GPS tracking, and more are now packaged in a more precise, reliable, and efficient Smart Collection Package.



Tailgates ranging from 1 yd<sup>3</sup> to 4 yd<sup>3</sup> based on body capacity

Over-the-top dumping system

Separators made of recycled plastic easily movable by hand

Wind deflectors on both sides of the hopper

Multi-feature body controls are conveniently accessible from both sides

30 yd<sup>3</sup> to 48 yd<sup>3</sup> body sizes available

Auto-lock cart attachments available on loading buckets

18" deep loading bucket available curbside and streetside

1000 lb bucket lift capacity

	AUTOMATED	MANUAL	RESIDENTIAL	COMMERCIAL	DEMOLITION	ORGANICS	ALLEYS TIGHT AREAS	RECYCLING	TIPTO DUMP	FULL EJECT	SPLIT BODY	50>82 DGE	50>96 DGE	50>100 DGE	60>97 DGE	FRAME	ROOF	CAB	TAILGATE	EV	
Top Select		●	●			●		●	●			◆ CNG						◆ CNG		●	





## **CURBSIDE RECYCLING PIONEERED BY LABRIE**

Streamline collection with 2-7 compartments for precise sorting. Unique over-the-top dumping. Add optional cart attachments for easy roll cart pick-up.



## **EASY, SAFE 1-MAN OPERATION**

The Top Select offers versatile operation with multiple driving configurations, enabling efficient one-man operation. Stand-up drive positions on either or both sides of the truck are available for added convenience and safety.



## **MAXIMUM PRODUCTIVITY**

The Top Select is equipped with dual hydraulic cylinders featuring adjustable cushions for seamless operation of the loading bucket.

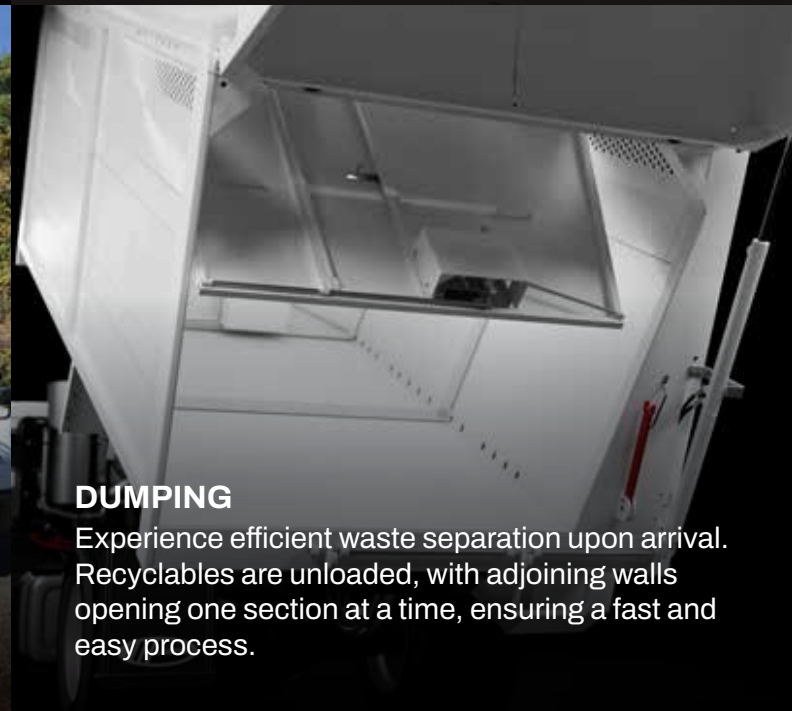

## **DUMPING**

Experience efficient waste separation upon arrival. Recyclables are unloaded, with adjoining walls opening one section at a time, ensuring a fast and easy process.

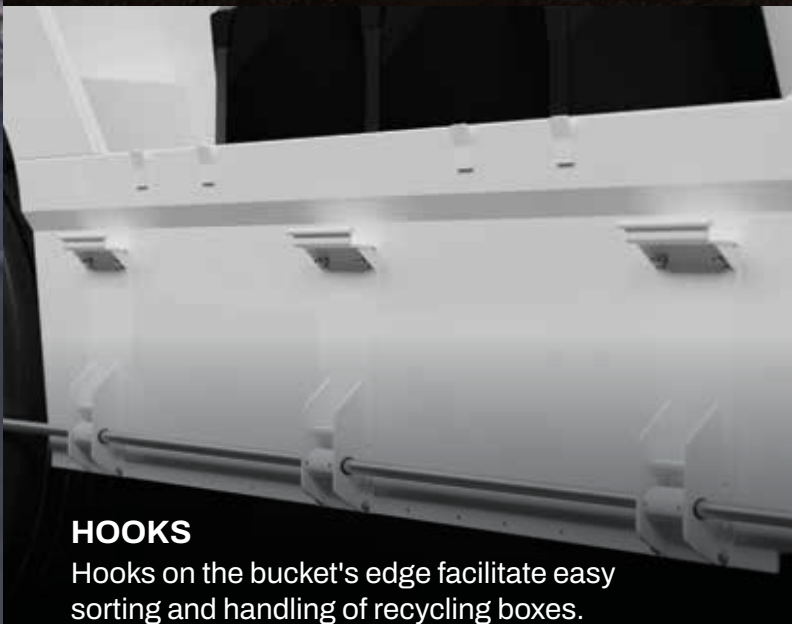

## **HOOKS**

Hooks on the bucket's edge facilitate easy sorting and handling of recycling boxes.

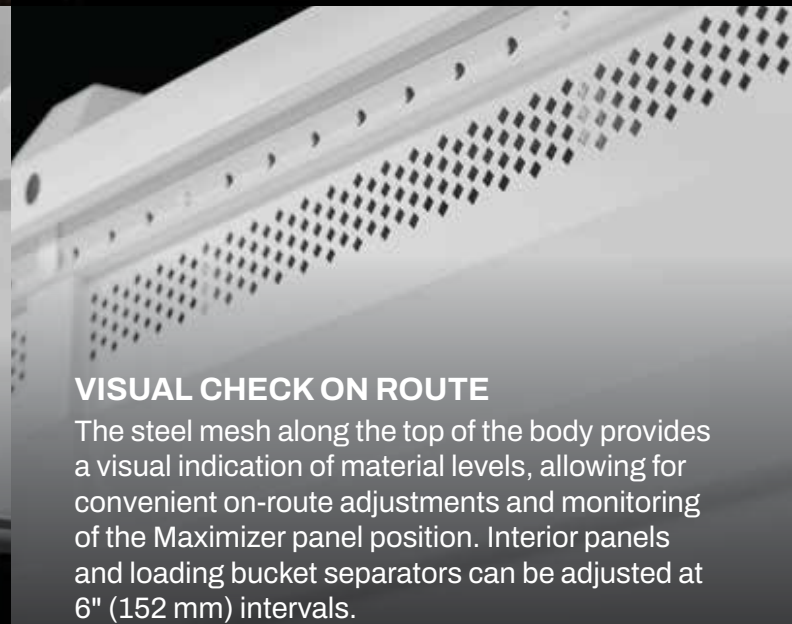

## **VISUAL CHECK ON ROUTE**

The steel mesh along the top of the body provides a visual indication of material levels, allowing for convenient on-route adjustments and monitoring of the Maximizer panel position. Interior panels and loading bucket separators can be adjusted at 6" (152 mm) intervals.

# Top Select™ Specifications

## Body Specifications

Body Floor	3/16" 50W 50,000 psi
Body Sides	12ga A1011 CS
Body Roof (fixed)	12ga A1011 CS
Body Roof (mobile)	12ga A1011 CS
Tailgate	12ga A1011 CS

## Hydraulic Specifications

Pump	Gear
Pump Capacity	16.5 gpm @ 700 rpm
Max. Operating Pressure	2,000 psi
Oil Reservoir	35 gal

## Maximizer (for compartment optimization<sup>1</sup>)

Forward Force on Recyclables	40,000 lbs
Rearward Force on Paper	18,000 lbs

<sup>1</sup>Not intended for compaction

## Cylinder Specifications

Body Lifting Cylinder (short deck)	4 stages 6-1/16" bore x 150" stroke
Body Lifting Cylinder (long deck)	4 stages 6-1/16" bore x 180" stroke
Loading Bucket Cylinders	3-1/4" bore x 1-1/2" rod x 15-1/2" stroke
Maximizer Cylinder	5" bore x 3" rod x 84" stroke
Tailgate Cylinders	2-1/2" bore x 1-1/2" rod x 28" stroke

## Loading Bucket Specifications

Lifting Capacity	1,000 lbs
Loading bucket width	18"
Loading height above frame	7"

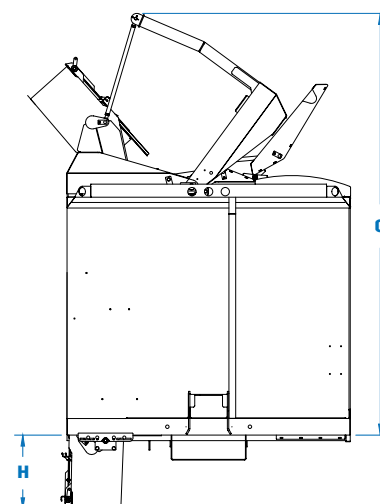
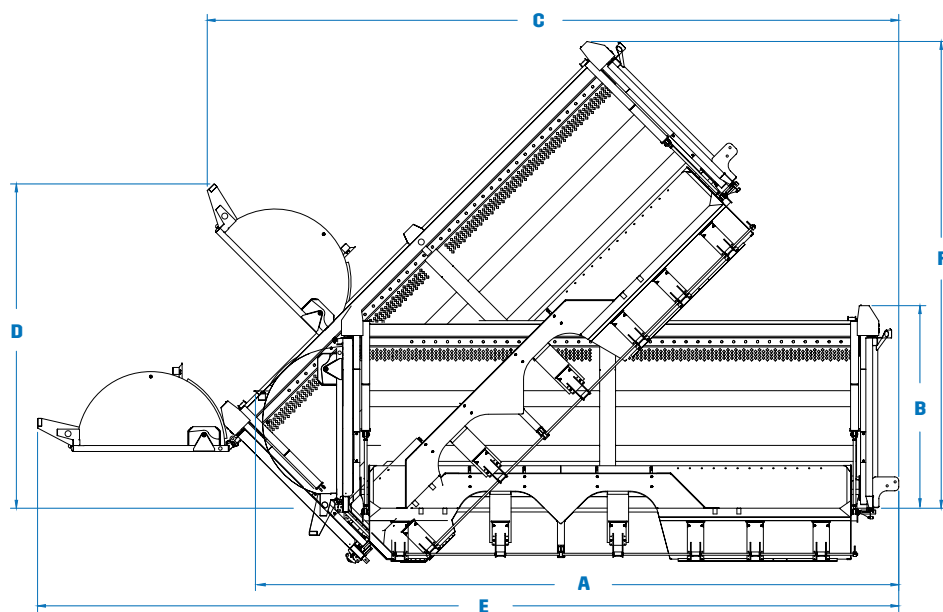

## Body Dimensions (Top Select 1000)

	34yd <sup>3</sup> (31+3)	42yd <sup>3</sup> (38+4)	45yd <sup>3</sup> (44+1)	48yd <sup>3</sup> (44+4)
A. Overall Length, Tailgate Closed (in.)	281	288	298	324
Overall Width (in.)	102	102	102	102
B. Overall Height Above Frame, Tailgate Closed (in.)	90	102	102	102
C. Overall Length, Tailgate Open (in.)	305	312	352	348
D. Overall Height Above Frame, Tailgate Open (in.)	137	163	158	163
E. Overall Length, Dumping Position (in.)	374	397	433	433
F. Overall Height Above Frame, Dumping Position (in.)	201	209	235	235
G. Overall Height Above Frame When Dumping (in.)	124	152	152	152
H. Distance between bottom of bucket and chassis frame rail (in.)	27	27	27	27

## Performance Specifications

Bucket complete cycle time	15 - 17 sec @ 700 rpm
Maximizer complete cycle	28 - 35 sec @ 700 rpm
Tailgate Open	18 sec @ 700 rpm
Tailgate Close (with Safety Flow limiter)	20 sec @ 700 rpm
Body Up (depending on body size)	30-45 sec @ 1500 rpm
Body Down (depending on body size)	25-100 sec @ 700 rpm

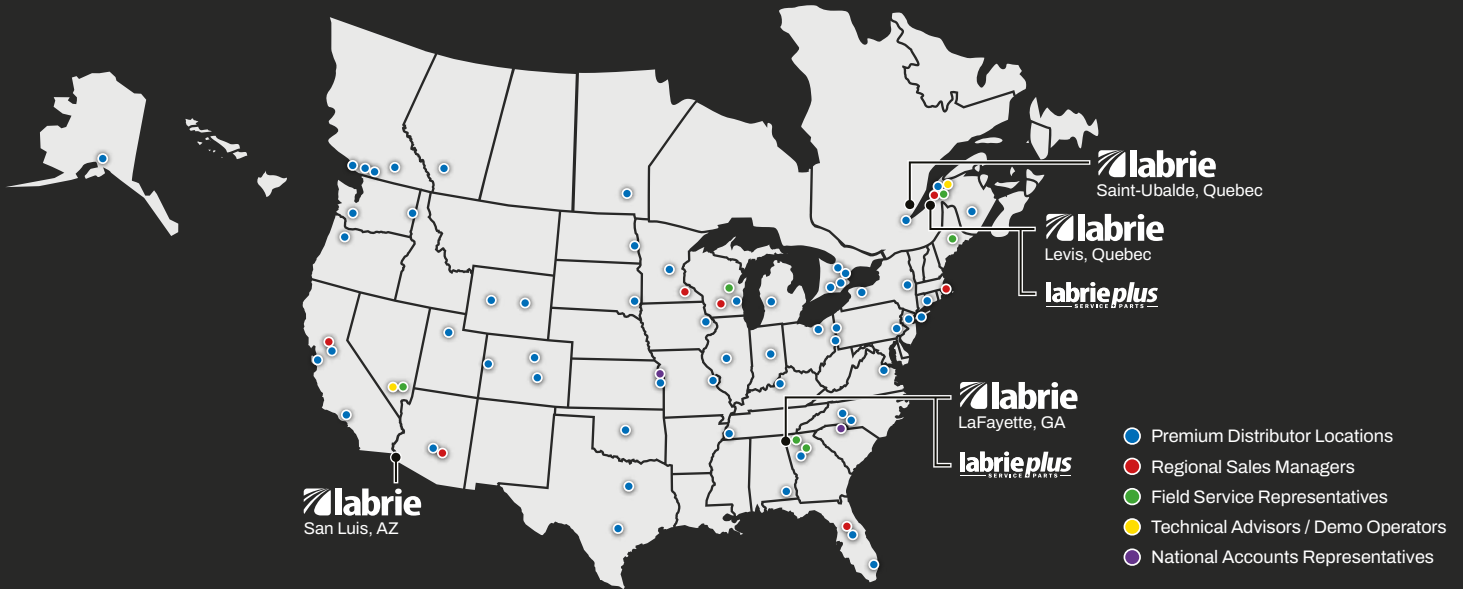

## Our North American network is dedicated to quality.

Labrie™ trucks are supported by over 30 top-tier distributors spanning across 50+ sites in the US and Canada, guaranteeing a commitment to driving excellence and providing expert support.



Opt for the Labrie™ Pronto Stock Program when a pre-built model makes sense. Benefit from expedited delivery, cost savings, and a wide selection of models designed to cater to even the most demanding collection needs.



With Sourcewell, save time and money by combining the buying power of more than 50,000 government, education, and nonprofit organizations.



# DRIVE EXCELLENCE™



175-B, route Marie-Victorin, Lévis, Quebec, Canada, G7A 2T3  
 Toll Free: 1-800-463-6638 | Telephone: 418-831-8250  
 sales@labriegrup.com | www.labriegrup.com



**United States of America**  
 1198 Shattuck Industrial Blvd, Lafayette, GA, 30728  
 Toll Free: 1-800-231-2771  
 usa.labrieplus.com | partscenter@labrieplus.com

**Canada**  
 175-A, route Marie-Victorin, Lévis, Quebec, Canada, G7A 2T3  
 Toll Free: 1-877-452-2743  
 canada.labrieplus.com | labrieplusqc@labrieplus.com