

ELGIN[®]

Subsidiary of Federal Signal Corporation

Eagle[®]



ELGIN EAGLE®

RELIABLE, HEAVY DUTY, VERSATILE MECHANICAL BROOM SWEEPER

If you need a proven mechanical broom sweeper with reliable heavy duty performance, high dump capability and superior operator comfort look to the Elgin Eagle®. The Eagle, first introduced as part of the Elgin family of sweepers in 1988 has been continuously improved, retaining all of the features that made it popular. These include a simplified dual-engine design, increased operator efficiency and productivity, along with the latest technology for superior results.

If you haven't tried sweeping with the Eagle – now is the time to take another look.



APPLICATION SOLUTIONS

Elgin Sweeper doesn't offer just one sweeping technology — we take an application-based approach to solving our customers' sweeping needs. Our team works with each customer to ensure that you get a machine that fits your specifications, with the right truck, engine configuration, fuel requirements, and options.

POWERFUL SUPPORT

Elgin sweepers are built for clean, backed for life. Throughout the life of the sweeper, we offer training to your team on proper use and maintenance. We have a world-wide network of experienced dealers with factory trained technicians and a local stock of OEM parts and accessories, to ensure total customer peace of mind.

UNMATCHED QUALITY

The Eagle was introduced 25 years ago and has been continuously improved. Manufactured in an ISO:9001 certified plant, Elgin Sweepers are quality inspected and functionally tested prior to shipment. Paint prior to assembly ensures uniform, durable coverage. Eagles are proudly assembled in the U.S.A.



HIGH PRODUCTIVITY SWEEP SYSTEM

- Mounted on a selection of conventional or commercial cabover chassis. Conventional chassis feature a five speed overdrive automatic transmission and commercial cabover chassis feature a six speed wide ratio automatic transmission.
- Sweep system is powered by a low emission, 74hp Cummins diesel engine, (55 kW @ 2500 RPM), one of the most powerful standard auxiliary engines available on a mechanical sweeper.
- Control console, located between the operator stations, provides quick, easy access for increased productivity and safe operation.
- Dual free-floating gutter brooms adjust to variable road surfaces, a sweep path of 10 feet (305 cm) and a powerful free floating direct-drive main broom, ensure reliable and complete pickup of debris.
- Superior dust control is maintained with an in-cab zone-controlled diaphragm water pump and a 360 gallon (1363 L) water tank for long sweep times between refills.
- 4.5 cubic yard (3.4 cubic meters) hopper features a center mounted double-scissors lifting mechanism for greater stability and trouble-free operation. Dumping height is variable up to 10 feet (305 cm) and an 11 inch (279 mm) side shift enables a cleaner more efficient unloading of material.
- Flexible range of chassis choices including cabover or conventional chassis. The cabover chassis cab is dualized with OEM parts, including full factory controls, steering, and OEM gauge package that is identical for both left and right operator stations.



EASY TO OPERATE. EASY TO MAINTAIN. BUILT TO LAST.



MAIN BROOM

A free-floating trailing arm main broom conforms to road contours. Powered by the auxiliary engine, the main broom works at variable speeds that coincide with auxiliary engine RPM. Productivity is enhanced with automatic settings for down pressure, and wear control. Main broom lift, lower and down-pressure functions are controlled from the cab. The main broom arm bearings are sealed and self-aligning for self-adjustment when experiencing an uneven load. The self-adjusting system guards against premature wear.

SIDE BROOMS

46 inch (1168 mm) trailing arm, free-floating side brooms offer four-way motion and protection against damaging impacts. Pneumatic lift and extension control enhances performance while sweeping within a 10 foot (305 cm) wide path. Steel plate disc construction adds durability. Broom speed is controlled by hydraulic motors operating at variable speeds that coincide with auxiliary engine RPM. Automatic settings control down-pressure, digging-pressure and wear-control. In-cab side broom pressure gauges and down-pressure control are standard.



NO JAM DEBRIS CONVEYOR

The Eagle's conveyor comes standard with the Chevron Belt. This unique belt design uses molded-in full-width angled cleats that move large debris without jamming. High-strength belt material provides long wear and maximum uptime. The conveyor is controlled from in-cab, including reverse. A built-in washdown makes cleanup quick and easy.



AUXILIARY ENGINE

A low-emission 74 hp Cummins diesel engine (55 kW @ 2500 RPM) provides variable control over sweeper functions independent of the chassis. It is among the most powerful standard auxiliary engines available on a mechanical sweeper. Max fuel capacity is 50 gallons (189 L). The engine includes a two-stage, dry-type air cleaner with safety element, pre-cleaner, and optional in-cab restriction indicator. In-cab gauges and warning lights are displayed for all engine functions including tachometer, hour meter, volt meter, fuel level, coolant temperature, oil pressure, hydraulic oil filter restriction, engine running, and air filter restriction.

HYDRAULIC SYSTEM

The Eagle features a 34 gallon (128 L) reservoir with an external level indicator and thermometer, and a 13.5 GPM (51 LPM) triple section gear pump capacity at 1200 RPM of the auxiliary engine.



SIMPLE, EASY-ACCESS MAINTENANCE

The Eagle was designed so that systems are accessible and easy to service. Large access doors allow for 180 degree accessibility to engine maintenance components. The hydraulic system with o-ring face seal fittings is designed for long life and leak-free operation. Heavy-duty waterproof electrical connectors and color-coded wires have stamped identification for quick location during troubleshooting. A stainless steel toolbox provides additional storage.

SUPERIOR MECHANICAL SWEEPER DESIGN

LARGE VARIABLE HEIGHT DEBRIS HOPPER

The Eagle features a variable-height, right side dump hopper with a capacity of 4.5 cubic yard (3.4 cu meters) volumetric. All hopper lift and dump controls are hydraulic and easily operated from in-cab console mounted controls. A 50 degree dump angle allows material to easily slide out.

A unitized, twin-cylinder, double scissors lift rated at 11,000 lbs (4990 kg) unloads material at a minimum of 38 inches (965 mm) and a maximum of 10 feet (3048 mm). Payload capacity is 10,000 lbs (4536 kg) per load. An 11 inch (279 mm) side shift allows material to be unloaded into the center of a truck or container for cleaner dumping. A full hopper can dump and retract in 20 seconds for short intervals and up to 70 seconds at top height.



SUPERIOR DUST SUPPRESSION

A 360 gallon removable water tank is made of corrosion resistant polyethylene. A 16 foot, 8 inch long (5.1 m) fill hose and water level indicator lights located on the control console are standard. Water flow for the side and main brooms is controlled in-cab. The self-priming diaphragm pump (run dry type, 40 psi) provides effective dust control. Three spray nozzles are positioned on each side broom and three on the main broom.

MEMORY SWEEP®

Elgin's exclusive Memory Sweep feature allows the operator to resume all previous sweeper settings, even broom tilt if so equipped, with one touch control. This feature enhances operator productivity and reduces operator fatigue. Memory Sweep incorporates a multi-screen display that indicates engine hours and water tank level as well as system diagnostics. This screen also displays optional features such as broom tilt angle and broom hours.



UNIQUE APPLICATION VERSATILITY

*PATENTED CONVEYOR FLEXIBILITY

The Eagle comes standard with a no jam debris conveyor belt featuring molded-in full-width cleats that move debris without jamming. High-strength belt material provides long wear and maximum uptime. The Eagle is specifically designed to provide versatile and reliable performance in a wide range of applications including highway sweeping, general municipal sweeping, trash, leaves, and other organics.

The Eagle is also available with a squeegee-type conveyor for applications such as aggregate and granular material pick up of gravel and millings; ideal for road construction contractors. Conveyor rotation direction is controlled in-cab and conveyor speed is variable with auxiliary engine RPM providing maximum on-the-go productivity and ease of cleaning.

THE ELGIN BELT CONVEYOR

- Standard new Chevron Belt.
- Full-width angled cleats move more material quickly to hopper for maximum productivity.
- Direct-drive hydraulic motor for optimal power transfer to the conveyor system.
- Improved hopper fill by throwing debris towards center of hopper.
- Heavy-duty poly/nylon belt construction resists stretching and requires fewer adjustments.
- Ribs between cleats enhance effectiveness of moving fine debris into the hopper.

THE ELGIN SQUEEGEE CONVEYOR

- Chain side-plate constructed from through hardened steel for long life and smooth operation.
- Three-piece design for easy service without removing complete assembly.
- Thick, multi-ply rubber-edged flights provides efficient movement of debris into the hopper.
- Unique, interlocking, wavy-plate joint design prevents excessive wear and "thumping" over plate seams.
- Abrasion-resistant steel floor for durability.
- Direct-drive hydraulic motor for optimal power transfer to the conveyor system.

The Eagle conveyors are designed to be interchangeable should a customer have different applications throughout the sweep season.



WATERLESS DUST CONTROL

The Elgin Eagle is available with an optional dry dust control system. This model maintains all the features and performance that have made the Eagle a popular four wheel mechanical sweeper, but does not require water for dust suppression. This means increased pick-up of fine particles over wet dust control sweepers, reliable year-round sweeping, and considerable water conservation. The Eagle with dry dust control's patented dust control system includes a dust skirting system, dust separator in the hopper, and a dust control fan with a maintenance-free filter. Operators sweep more and spend less time filling tanks, enhancing productivity. This model is ideal for industrial applications where heavy, dry materials must be swept up while keeping dust emissions to an absolute minimum. *Consult factory for waterless model details.*

*U.S. Patent No. 9, 121, 150

OPTIONAL ENHANCEMENTS



CONVENTIONAL CHASSIS

Conventional chassis are built for sweeping and provide outstanding visibility, comfort, safety, and productivity. The short wheel base and unique steering geometry allow maximum maneuverability. A choice of Freightliner or International conventional chassis are also available.



LIFELINER® HOPPER SYSTEM

The LifeLiner® hopper system is a specially designed hopper liner and finish system that greatly improves the life, durability, and functionality of a sweeper hopper. The LifeLiner hopper system is backed by a lifetime warranty.*



IN-CAB SIDE BROOM TILT AND EXTENDED REACH

Allows operator to sweep effectively in variably-pitched gutters. On-the-go pitch adjustment with a simple variable rocker switch. Extended reach allows the side broom to follow curbs and tight cul-de-sacs.

ADDITIONAL OPTIONS:

- Outside cab, side broom down pressure control
- In-cab, side broom speed control
- Automatic lubrication system
- Outside cab, main broom down pressure control
- Strobe lamp
- Front spray bar
- Arrowstick
- Alternative Conveyor - Squeegee with rubber edging

SPECIFICATIONS:

SWEEP PATH

Main broom only:
60 in (1524 mm)

Main broom & one side broom:
90 in (2286 mm)

Main broom and 2 side brooms:
120 in (3048 mm)

HOPPER CAPACITY

Volumetric Capacity: 4.5 yd³ (3.4 m³)
Material volume: 3.3 yd³ (2.5 m³)

HOPPER DUMPING

Minimum dump height: 38 in (965 mm)
Maximum dump height: 10 ft (3048 mm)

WATER SPRAY SYSTEM

Tank capacity: 360 gal. (1362 L)

AUXILIARY ENGINE

Cummins 74hp EPA compliant engine

CHASSIS

Conventional or cab-over

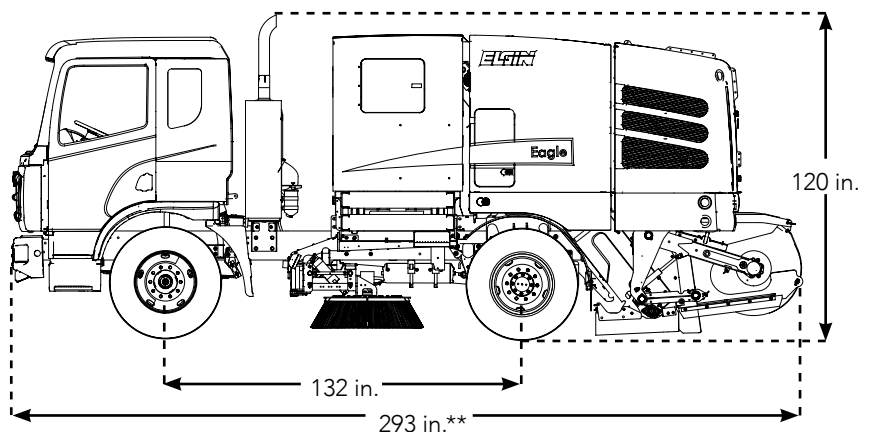

*Consult factory for warranty details **Transport mode

ELGIN SWEEPER IS YOUR PARTNER...

IN THE PLANNING

Instead of one-size-fits-all solutions, we'll work with you to select the sweeping technology that fits your specific needs.



IN THE STREETS

We're here to help you maintain your Elgin and train your operators to ensure the job is done right.



INTO THE FUTURE

Our dealers don't just sell you an Elgin; they're available to answer your questions and provide service for the life of the machine.



WARRANTY

Elgin Sweeper Company backs the Eagle sweeper with a one-year limited warranty. The Eagle is warranted against defects in material or workmanship for a period of 12 months from the date of delivery to the original purchaser. Optional extended warranty packages are available. Consult your Elgin dealer for complete warranty information.

Your Local Elgin Dealer Is:



1.800.263.1262 | jjei.com
info@jjei.com



elginsweeper.com

1300 W. Bartlett Road • Elgin, IL 60120 U.S.A.

Specifications subject to change without notice. Some items shown may be optional. Elgin®, Eagle® and LifeLiner® are registered trademarks of Elgin Sweeper Company.

©2015 Elgin Sweeper Company. Effective 10/15 P/N 0705394-A