

## Extremely Serviceable

Fewer parts ... faster servicing. No special tools or equipment required.



- 5-minute packing change



- 15-minute pop-out valve cartridge change

## Remarkably Versatile

Tackle varied applications in less time with one convertible system



- On-site pressure conversion
- Slip-fit stuffing boxes
- Simple bolt-on conversion fluid ends

# The UNx™ Fluid End X-treme Advantage

Unmatched for performance and flexibility!

Contractors who live and breathe waterblasting performance demand the superior durability and flexibility of the UNx fluid end system. For ease of maintenance, in-the-field versatility, or overall operating efficiency, nothing beats the UNx system.

Engineered components streamline routine maintenance. Even operating pressures can be changed in minutes — from 5,000 to 40,000 PSI — with the UNx interchangeable fluid end design.

Now you've got the flexibility to tackle all jobs, the efficiency to keep operating costs low, and the superior performance to optimize productivity hour after hour, day after day.

## Fewer Parts, Fewer Problems



## Simple & Dependable

### Uni-Valve Cartridge

- self-contained suction and discharge valve assembly
- slip-fit for easy maintenance
- in-line design minimizes turbulence

### Swing-Down Manifold

- easy access to valves
- weep holes indicate source of seal leaks

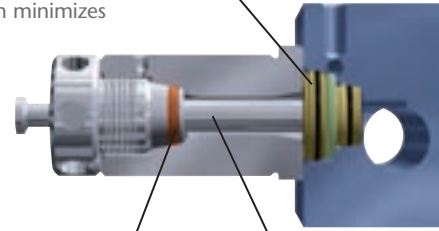

### Uni-Pak™ Plunger Packing Set

- one-piece packing
- tapered for easy removal
- water lubricated — no oil

### Clamp-Style Plungers

- specifically designed for the rigors associated with each operating pressure
- clamp-on design for easy maintenance



X-Series diesel waterblast systems are available in both skid and trailer configurations. For unusual applications or configurations, Jetstream can offer custom solutions to meet your exact needs.

## X-Series Diesel Specifications

		6,000	7,500	10,000	12,500	15,000	20,000	30,000	36,000
X3000 Series	110 HP	Pressure (psi) 11	7,500 10	10,000 9	12,500 8	15,000 7	20,000 6	30,000 —	36,000 5
		Plunger Size (no.)							
		Flow (gpm)	23.2	18.4	14.9	11.8	9.9	7.4	—
X3600 Series	125 HP	Pressure (psi) —	7,500 11	10,000 10	12,500 9	15,000 8	20,000 7	30,000 —	36,000 5
		Plunger Size (no.)							
		Flow (gpm)	—	23.3	18.4	14.9	11.8	9.7	—
X4200 Series	150 HP	Pressure (psi) 15	7,500 13	10,000 11	12,500 10	15,000 9	20,000 8	30,000 —	40,000 —
		Plunger Size (no.)							
		Flow (gpm)	45.4	31.2	23.2	18.6	15.7	11.7	—
X4200 Series	170 HP	Pressure (psi) 15	7,500 13	10,000 12	12,500 11	15,000 10	20,000 8	30,000 7	40,000 6
		Plunger Size (no.)							
		Flow (gpm)	45.2	35.6	27.0	21.4	18.0	12.9	9.1
X4200 Series	215 HP	Pressure (psi) 15	8,000 13	10,000 12	12,500 11	15,000 10	20,000 9	30,000 7	40,000 6
		Plunger Size (no.)							
		Flow (gpm)	50.3	39.8	32.2	27.0	21.5	17.0	10.0
X4200 Series	250 HP	Pressure (psi) 16	8,000 15	10,000 13	12,500 12	15,000 11	20,000 10	30,000 8	40,000 7
		Plunger Size (no.)							
		Flow (gpm)	62.1	48.6	38.7	31.3	26.3	19.4	11.9
X4200 Series	325 HP	Pressure (psi) —	8,000 16	10,000 15	12,500 13	15,000 12	20,000 11	30,000 —	40,000 8
		Plunger Size (no.)							
		Flow (gpm)	—	62.1	50.1	39.7	32.0	25.1	—

## Your Waterblast Solutions Provider



### Electric

Ideal for waterblast applications within process plants, industrial operations and military environments. Available as stationary skids or steerable in-plant trailers.



### 5000Q

The most versatile and cost effective 500 horsepower waterblast system available.



Compact design diesel waterblast systems are engineered to meet stringent, European equipment requirements. Available from 125 to 300 horsepower with footprints as small as 4' x 7'.



### Offshore Skids

With a host of unique features, these machines are certified to perform to the rigorous offshore standards



Containerized advanced waterjetting systems combine an innovative pump with advanced controls and a host of engineered features.

The RightStart program provides personal training with the purchase of your new waterblaster. Classroom and hands-on instruction by a RightStart technician helps your operators learn to use your new equipment with optimum efficiency and safety right from the start.



For best assistance, contact Jetstream of Houston or your Regional Sales Manager to determine how to best serve your needs.

**FS Solutions**  
Ohio Service Center  
1144 Expressway Dr. – South  
Toledo, OH 43608

**FS Solutions**  
Texas Service Center  
2500 E. Pasadena Frwy  
Pasadena, TX 77506

**FS Solutions**  
Alabama Service Center  
8584 Borden Ave.  
Leeds, AL 35094

**FS Solutions**  
California Service Center  
1510 Hayes Ave.  
Long Beach, CA 90813

**FS Solutions**  
Louisiana Service Center  
3111 S. Darla Ave.  
Gonzales, LA 70737

1.800.263.1262 | [jjei.com](http://jjei.com) | [info@jjei.com](mailto:info@jjei.com)

Catalog 20044  
P/N J70394  
Effective 8/2009

Copyright Jetstream of Houston, LLP ©2009



**Joe Johnson**  
Equipment  
Subsidiary Of Federal Signal Corporation



The X-treme Duty Line  
of Waterblasting Systems

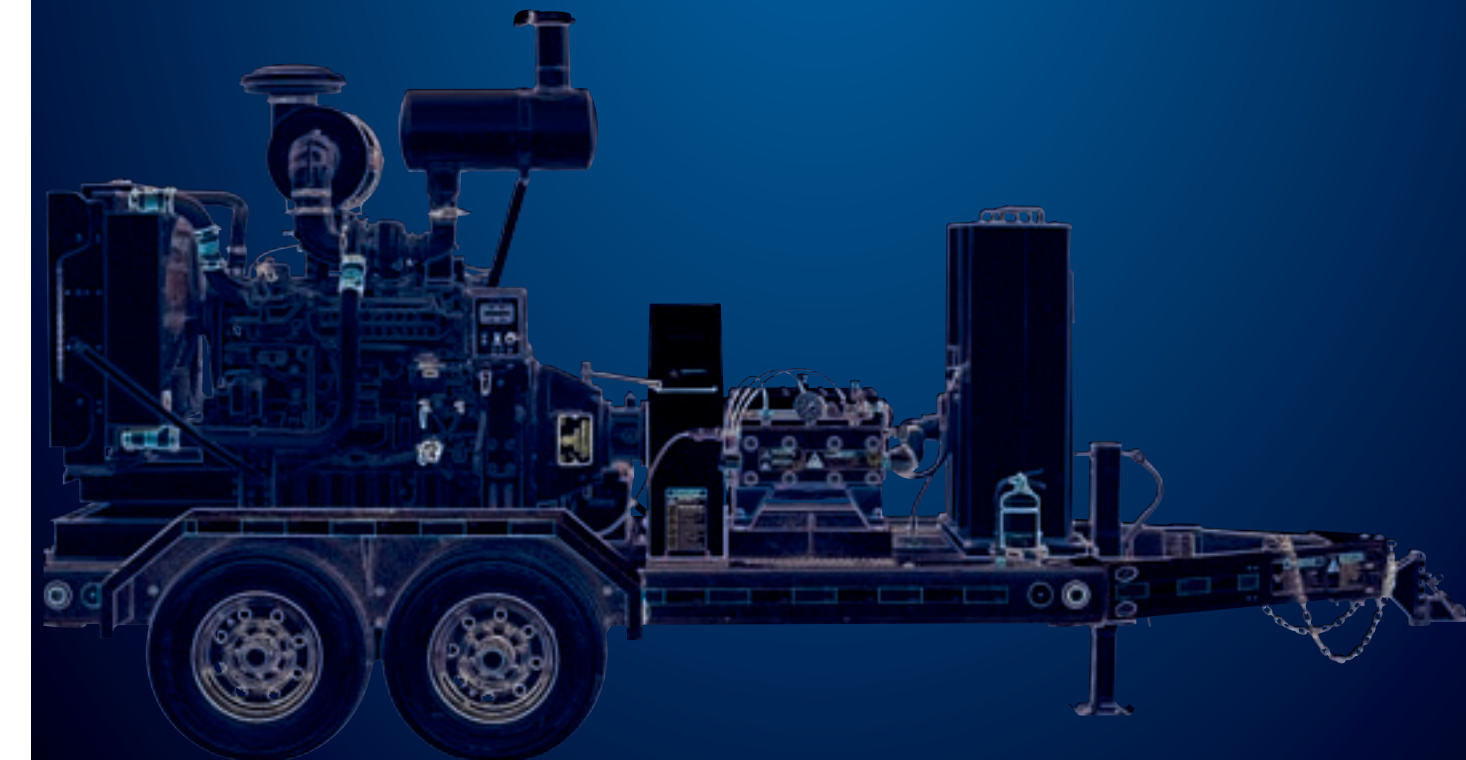

Jetstream Diesel Waterblast Units – The Contractor's Choice



# The X-Series waterblasting systems from Jetstream are engineered to outperform and outlast any other unit of its kind.

What happens when Jetstream takes the toughest waterblasting system in the industry and improves it from end to end? You get an X-treme duty unit with enhanced performance ... superior durability ... and unsurpassed operating efficiency. Welcome to Jetstream's X-Series waterblasting systems.

## The X-Series represents the best of the best in waterblast equipment.

The X-Series units deliver a host of engineered improvements. One of the most notable changes is the new Guardian™ water tank and filter system. The Guardian's integrated design helps extend system life, while larger filters help extend on-site operating time.

Like all Jetstream waterblast systems, the X-Series is built around the UNx™ Pump: the most efficient, easy-to-use, and versatile waterblast pump available.

You still have a choice of skid or trailer mounted units. And you still have Jetstream's exceptional customer service team and service facilities to support you day and night.

We invite you to explore all the enhancements and operating features of the Jetstream X-Series. Together, they can take your waterblasting operations to an X-treme level of performance and operating efficiency.



**High-Performance Diesel Engines**

- choice of John Deere, Cummins or Caterpillar
- open power unit keeps engine cooler and provides easy access for maintenance

**Safety Features**

- comprehensive safety decal package
- conspicuity tape surrounds entire frame

**High-Capacity Aluminum Fuel Tank**

- reduced dry weight
- resists corrosion
- longer runs between refueling

**Powerband Belt Drive**

- dual five band belts
- high torque carrying capabilities

**Power End Dependability**

- ductile iron power frame
- largest bearings in the industry
- high-strength crankshaft

## Greaseless Spread Bearing PTO

Heavy-duty bearings (spaced widely apart) and oil-bath lubrication differentiate this spread bearing PTO from the typical pilot bearing model. This field proven design offers highly reliable power transmission and reduced maintenance time. Now daily greasing is eliminated in favor of regular oil changes.

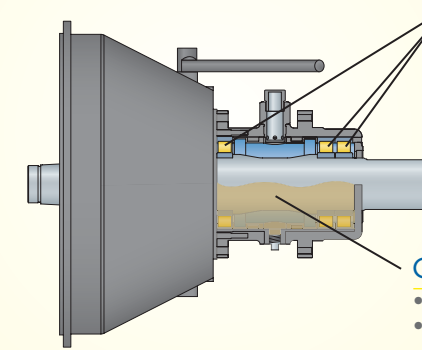

**Large Spread Bearings**

- opposing roller bearings provide reliable power transmission
- no pilot bearing — the "weakest link" in typical PTO's

**Oil Bath Lubrication**

- no daily greasing
- changed with engine oil



**Shorter Wheelbase**

- improves trailer travel through tight turns
- helps minimize tire scrubbing

**Forward Water Tank Location**

improves weight distribution with lower center of gravity

**Low Profile Trailer**

just 26" to top of frame for lower center of gravity

**Adjustable Hitch Height**

for safe, level hauling behind different vehicles

**Sealed Control Panel**

full instrumentation at your fingertips:

- hour meter
- tachometer
- oil pressure
- voltmeter
- water temperature

**Lifetime LED Trailer Lights**

- weather sealed
- corrosion resistant
- lights up faster, brighter

**10-gauge Galvanized Steel Fenders**

**EZ-Lube Hubs**

lubricate wheel bearings quickly via standard grease fitting

**Safety Shutdown Systems\***

protect against low oil pressure and high temperature

**Torsion-Style Axles**

smoother towing while providing lower trailer profile

**Hydro-Throttle Control\***

- saves fuel and engine wear
- manual throttle override to maintain set engine speed

**Improved Pump Access**

unobstructed access to fluid end for performing pressure conversion or routine maintenance

**UNx™ Fluid End**

Jetstream's patented system designed for fast conversion from 5,000 to 40,000 PSI operating pressures

**Trailer Wiring**

- completely weatherproof harness and connectors
- protective grommets runs

**Center-mounted Trailer Jack**

rated at 12,000 lb

## Diesel Unit Options

- stationary skid
- 6,000 to 40,000 PSI conversion kits
- Safety Watch remote shutdown system
- regulator valve for shut-in applications
- electric or hydraulic brakes
- gooseneck trailer
- spare tire package
- diamond-plate protective fender tops
- workbench and industrial strength vise
- forklift pads
- powder-coated or polished aluminum wheels
- packing lube water recirculation package
- charge pump\*\*
- engine enclosure
- air compressor package

- safety package
- fuel saving Hydro-Throttle
- special application units (i.e. oil field test pumps and hot water units)

### Accessories

Jetstream carries a full line of accessories for industrial waterblasting applications. Contact Jetstream for the latest accessories catalogs.

\*\* standard on models equipped with 40,000 PSI fluid end

## Jetstream's Guardian Waterblast Filtration System™

An integrated filter and water tank design that extends component life and increases operating uptime.

It's a fact: a quality water supply is critical to waterblast pump component life. Now the Guardian Filter System helps ensure a clean water supply — even when operating conditions vary.

Within this large, rugged tank, dual filters protect your waterblast pumps and components from abrasive dirt and contaminants. These extra long filters also require fewer filter changes — allowing you more time to get the job done!

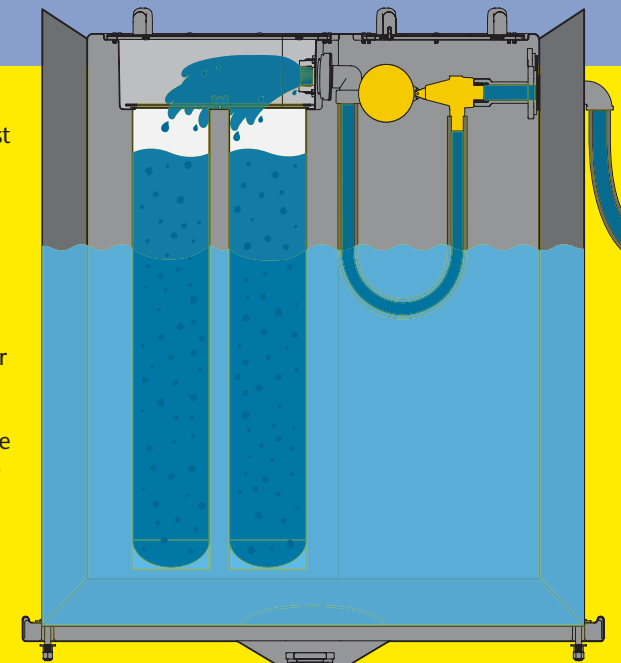

**Large, 100-Gallon Tank**

- large reservoir eliminates entrained air that can damage pump components
- lightweight and highly durable
- large inlet plumbing

**Dual 40" Filter Bags**

- 270% more filtration than standard #2 filter
- require less frequent replacement

**Large Flushing Port**

2" port drains entire water tank in just 90 seconds

**Hinged Lid**

easy access to filter bags

**Low-Water Shut-Down**

sealed float switch prevents pump cavitation



Protect waterblast pump components from contaminated water sources. The Guardian Filtration System is your best defense!

\* optional